

Automatic Pump Recirculation Valve PSG-N Type 75, 76, 77

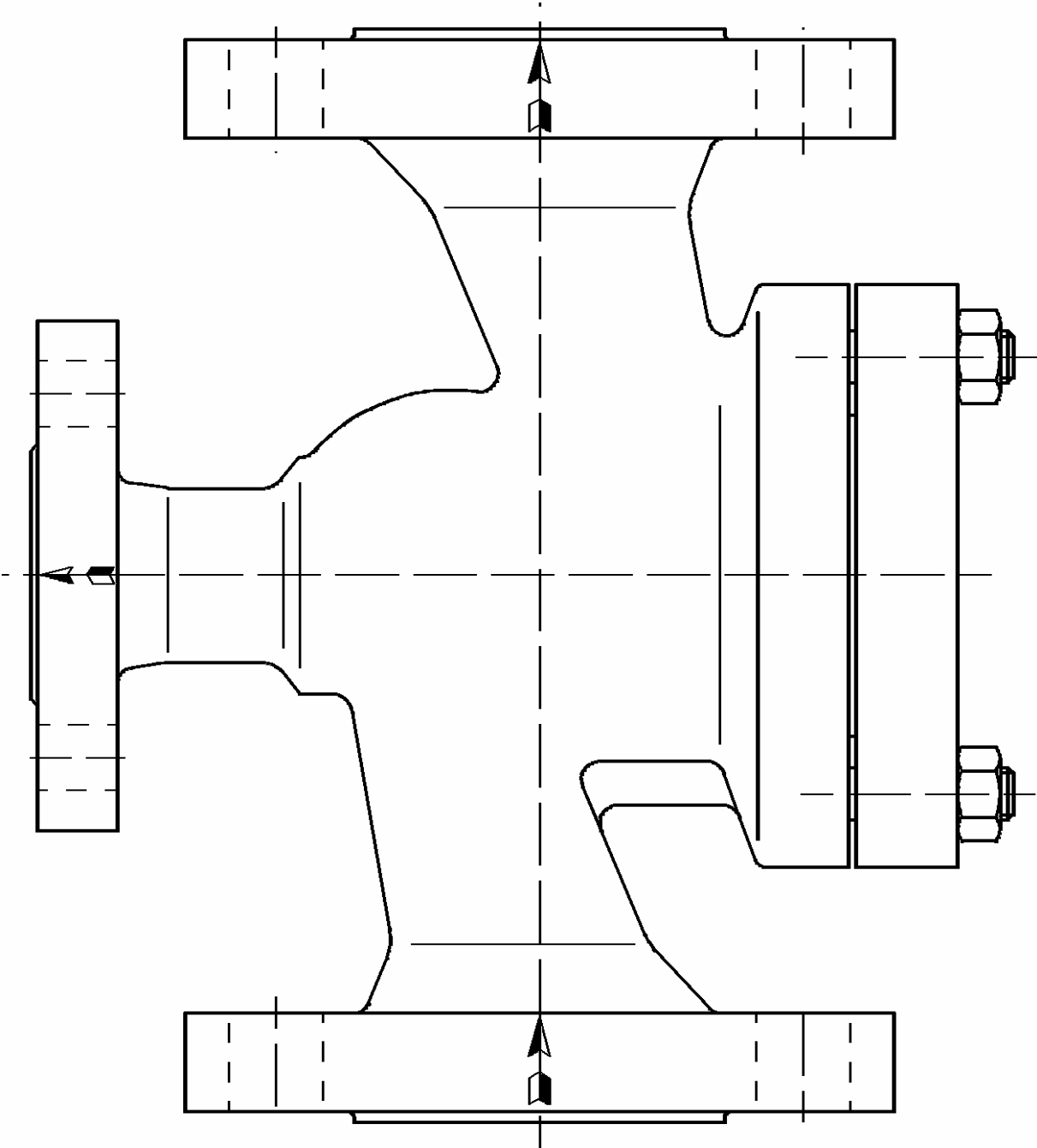

Excellence is our standard

Contents

1.	Automatic pump recirculation valves series PSG-N in "inline"-configuration	2
2.	Minimum flow control systems.....	3
3.	Function of the "inline" automatic pump recirculation valve PSG-N.....	4
4.	Advantages of the PSG-N "inline" construction.....	5
5.	"Inline" automatic pump recirculation valve PSG-N type 75 and 75-K.....	6
6.	"Inline" automatic pump recirculation valve PSG-N type 75-T	8
7.	"Inline" automatic pump recirculation valve PSG-N type 76 and 77	9
8.	PSG-N selection table for valve design acc. to PN-rating	11
9.	PSG-N selection table for valve design acc. to Class-rating	13
10.	"Inline" automatic pump recirculation valve with start-up flange (optional).....	15
11.	Back pressure increasing systems	17
12.	Flange specifications for HORA standard valves	17
13.	Markings	17
14.	Testing	17
15.	Rust protection.....	17
16.	Dispatch	18
17.	Storage.....	18
18.	Type coding PSG-N.....	18
19.	Formulas	19
20.	Notes.....	19
21.	Contacts.....	19
22.	Datasheet PSG-N	20

1. Automatic pump recirculation valves series PSG-N in "inline"-configuration

The automatic pump recirculation valves protect centrifugal pumps from possible damages caused by thermal and hydraulic overloads at low load operations by means of an automatic controlled bypassflow which corresponds with the required minimumflow of the pump.

The automatic pump recirculation valves of our series PSG-N have following specific features:

- Modulating bypassflow control
- Low noise single- or multistage pressure-letdown.
- Very servicefriendly thanks to the simple "inline" construction. Disassembly of all internals is possible without taking the valves out of the pipeline.
- Price advantages thanks to large stock availability and simple method of construction.
- The valves can be executed with all common flanges.

As a standard the valves are supplied in the sizes DN 32 (NPS 1,5) up to DN 200 (NPS 8) and pressure-ratings PN 10 up to PN 250 (CL 150 up to CL 1500) in cast steel material GP240GH+N (ASTM A 216 WCB). Upon request alternative sizes and materials can be quoted.

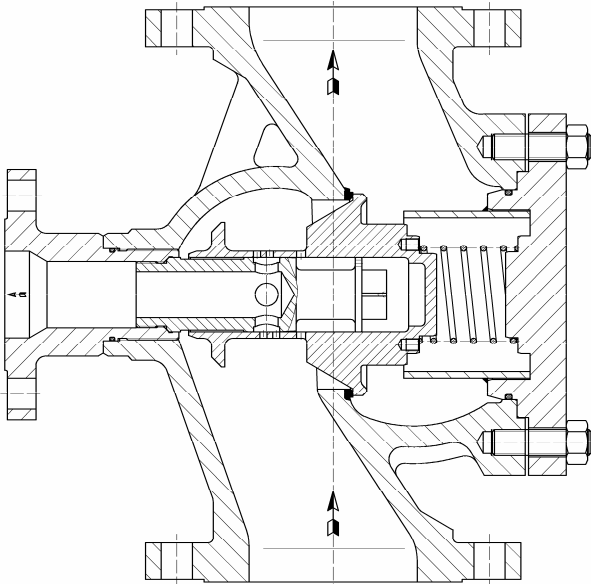

picture 1 Type 75

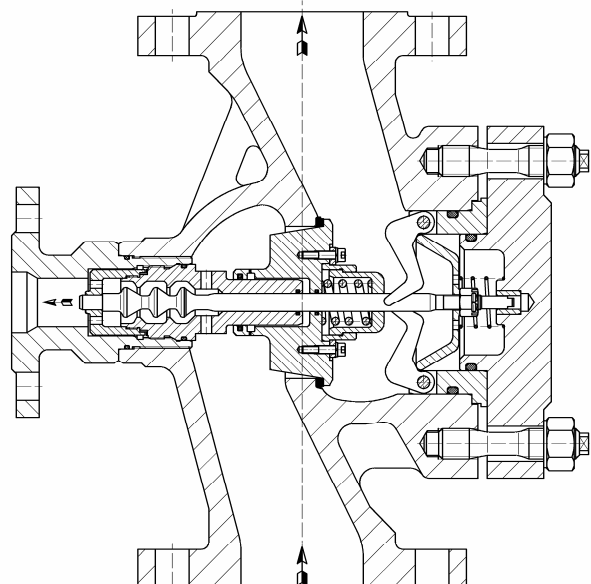

picture 2 Type 76



Excellence is our standard

2. Minimum flow control systems

All shown systems are available at HORA.

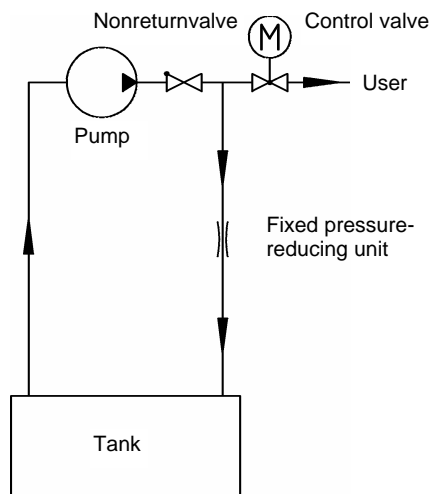

picture 3

Fixed pressure reducing unit in the bypass line

Advantage:
Low initial procurement costs.

Disadvantages:
High energy loss in combination with high operating costs due to continuous water circulation through the pressure reducing unit. A separate nonreturnvalve is required.

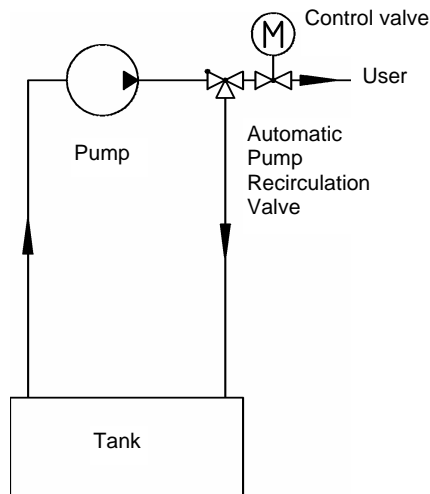

picture 4

Automatic Pump Recirculation Valve

Advantages:
No need for a separate nonreturnvalve.
No energy loss due to unnecessary bypass flow.
Compact configuration.
Service friendly because of the "inline" construction and the limited number of components.
Operation without external power supply.
Altogether the most cost effective solution.

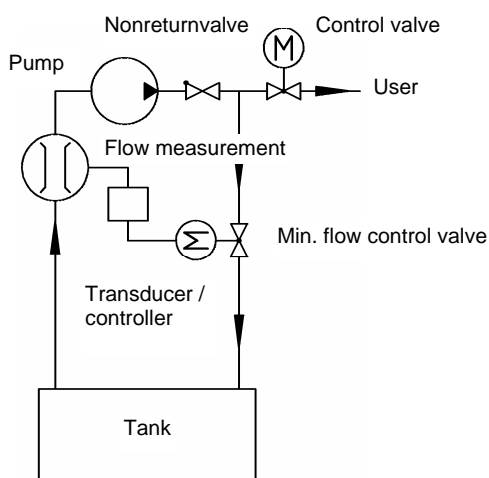

picture 5

Conventional system

Advantage:
No energy loss due to unnecessary bypass flow.

Disadvantages:
Service intensive due to large number of components. External power supply required. Separate nonreturnvalve required. High initial procurement costs



Excellence is our standard

3. Function of the “inline” automatic pump recirculation valve PSG-N

PSG-N (Type 75)
(Single stage)

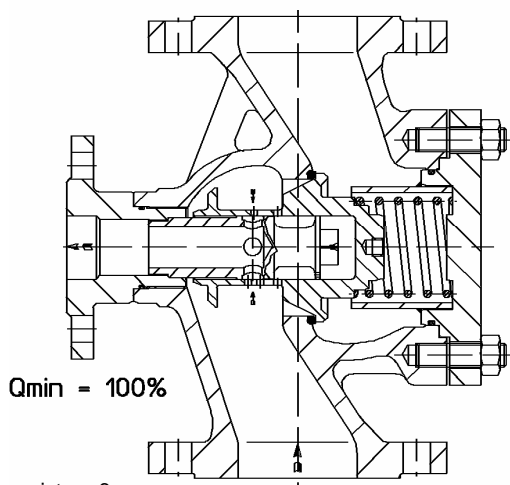

$Q_{min} = 100\%$

picture 6

PSG-N (Type 76)
(Multi-stage)

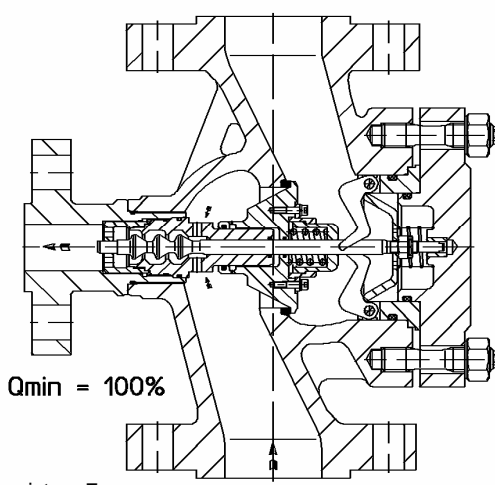

$Q_{min} = 100\%$

picture 7

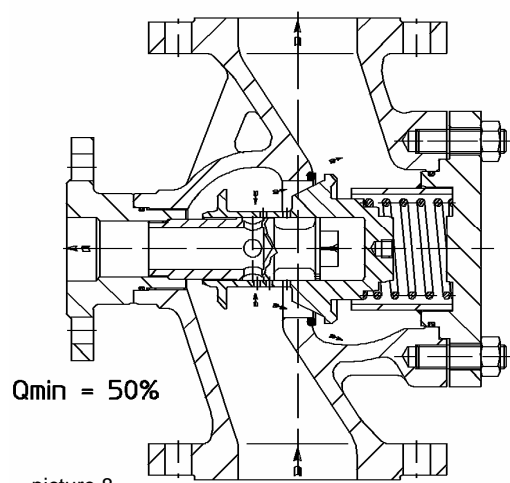

$Q_{min} = 50\%$

picture 8

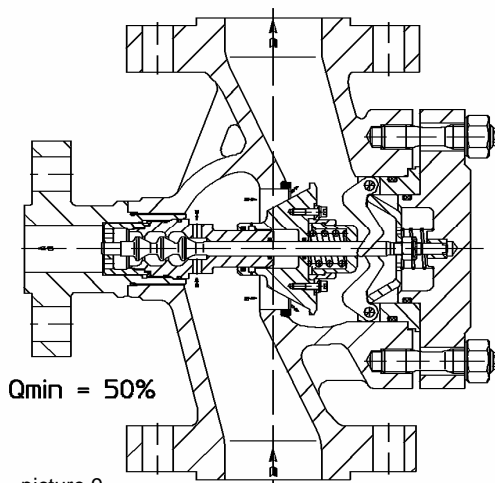

$Q_{min} = 50\%$

picture 9

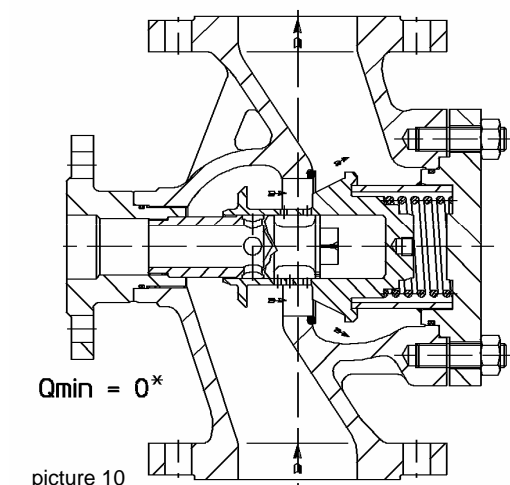

$Q_{min} = 0^*$

picture 10

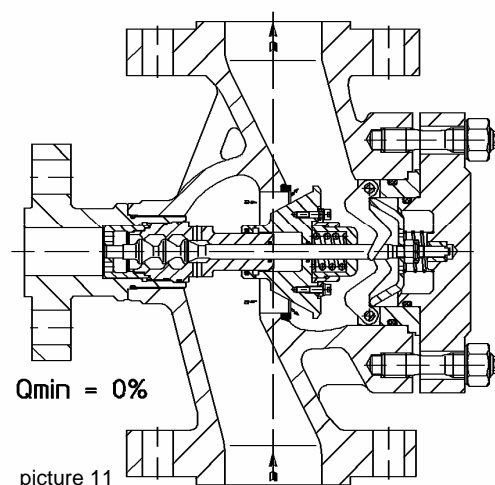

$Q_{min} = 0\%$

picture 11

*Note: Type 75 Small leakageflow



Excellence is our standard

The pictures 6 and 7 show the valves in closed position of mainflow (checkvalves in their seats). This situation occurs when the control valve in the processline is closed. Through the open area's (in the plug or along the seat bushing and control plug) the required minimum flow for the pump is reduced in pressure and led to the tank.

The pictures 8 and 9 show the automatic pump recirculation valves in a partly open position, (the checkvalve is partly lifted and the bypass is partly opened). This position is established when the pumpflow is split between the mainline and the bypassline to the tank.

The pictures 10 and 11 show the valves with their checkvalves in their upper, fully open position. The bypass is tightly closed, except for a tolerance related leakage flow with type 75. The full pumpflow runs to the tank. The type 75-K looks like type 75, only the diameter of the bypass bushing is smaller.

This modulating minimum-flow recirculation with the inline valve ensures trustworthy and smooth plant operation. Because the casted housing (one piece) contains a bolted-on cover, it is possible to reach the valve internals without the necessity of taking the valve out of the pipeline.

4. Advantages of the PSG-N "inline" construction

- The valve housing (one piece) doesn't have to be taken out of the piping, not even for revisions or inspection purposes.
- All parts can easily be exchanged after removal of the bolted-on cover. It can be purposeful to weld the valve into the pipeline. The valves can be supplied with butt-welding-ends.

The installation position of the valves has an impact on the valve layout and must be indicated in case of an order.

The layout is based on a valve installation within 1.5 meter from the pump outlet. Valves size DN 200 (NPS 8) and larger must be installed in a horizontal line with the bypass pointing downwards.

Valves should not be installed with the bypass pointing upwards.

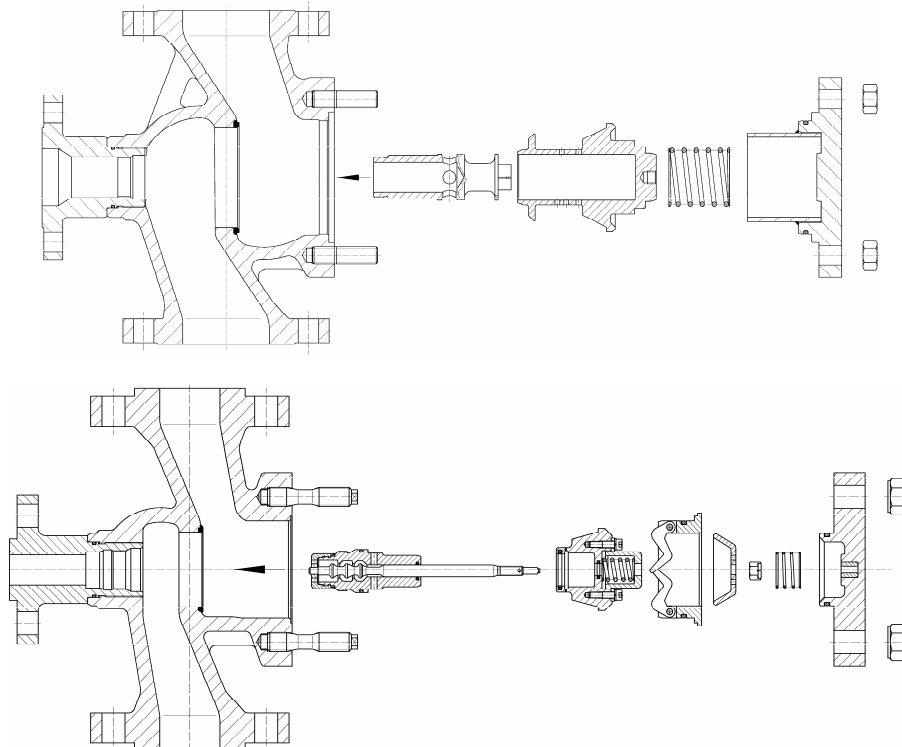

picture 12 Mounting of the valve internals



Excellence is our standard

5. "Inline" automatic pump recirculation valve PSG-N type 75 and 75-K

Design: Standard upto and including DN 200 / NPS 8 with many parts in stock

Service: Low-pressure range with a pressuredrop in the bypass up to 20 bar. Is a nonreturn valve or an orifice plate integrated in the bypass flange, the pressuredrop can be as much as 25 bar. The bypass closes normally at about 35% of the max. process-flow. Continuous operating in a range between +/- 10% around the closing point should be avoided. Normal operating points are 100% bypassflow and flows over +10% of the switchpoint. Leckagerate of the main checkvalve $\leq 0,01\%$ of the max. kv-value (EN 1349-IVL1)

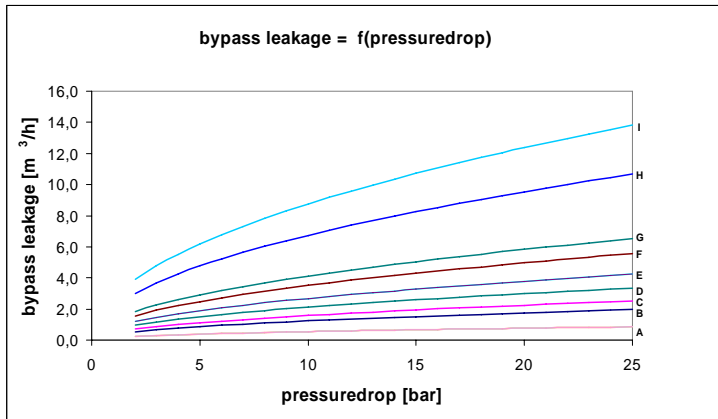

- A = DN32-DN100; NPS 1,5 - 4 (Type 75-K)
- B = DN32; DN 40; NPS 1,5 (Type 75)
- C = DN50; NPS 2 (Type 75)
- D = DN65; NPS 2,5 (Type 75)
- E = DN80-DN100; NPS3-NPS4 (Type 75)
- F = DN125; NPS 5 (Type 75)
- G = DN150; NPS 6 (Type 75)
- H = DN200; NPS 8 (Type 75)
- I = DN250; NPS 10 (Type 75)

picture 13 Bypass leakage of valve type 75 and 75-K (water 20°C)

Advantages: All parts can easily be exchanged, low pressurelosses

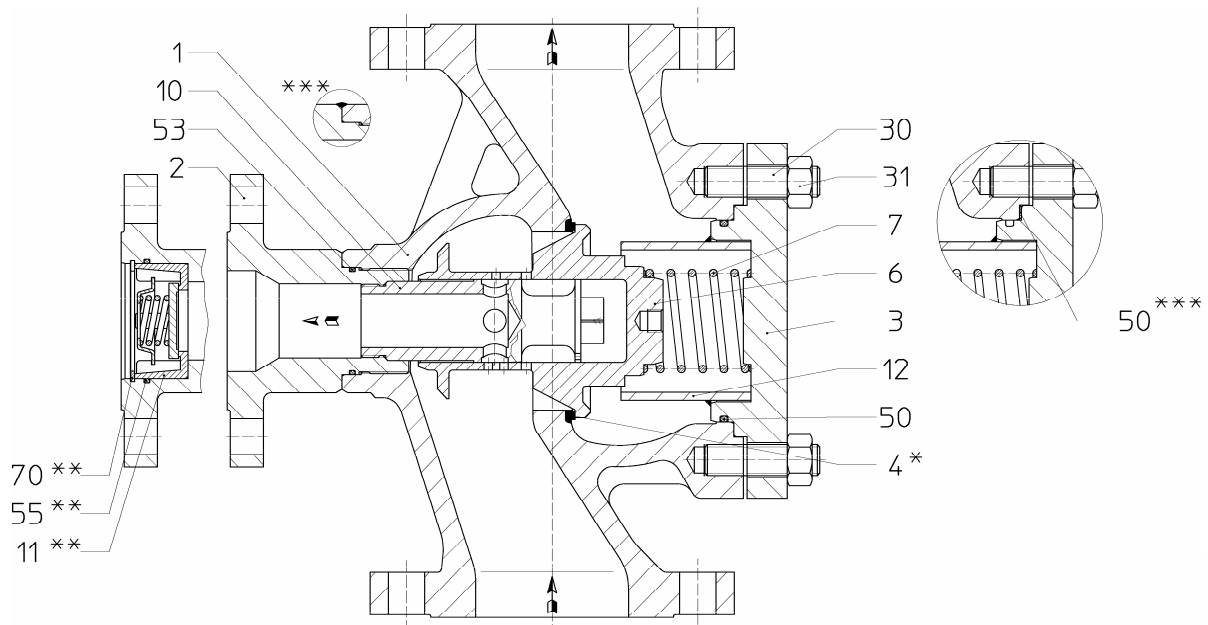

picture 14 PSG-N type 75

Pos.	Description	Material PN 16-40 / CL 150-300	Comparable with ASTM material	Spare parts
1	body	1.0619+N	A 216 WCB	
2	flange	1.0460	A 105	
3	cover	1.0460	A 105	
4	pressed seat *	1.4021	A276 Gr 420	
6	check valve	1.4122	(min. 13%Cr-steel)	x
7	helical spring	1.4571	A 313 Type 316	x
10	bypass bushing	1.4122	(min. 13%Cr-steel)	x
11	nonreturn valve**	1.4317	A 743-CA 6NM	
12	pipe (≥ DN 80; NPS 3)	1.0305	A 106	
30	stud bolt	1.1181	A 576 1045	
31	hexagon nut	1.1181	A 576 1045	
50	o-ring ***	EPDM/NBR	EPDM/NBR	x
53	o-ring ***	EPDM/NBR	EPDM/NBR	
55	o-ring **	EPDM/NBR	EPDM/NBR	
70	retaining ring **	1.4122	(min. 13%Cr-steel)	

Table 1: Partlist with standard material type 75 and 75-K

Bold face printing = stock parts up to and including DN 200 (NPS 8)
x= mark the standard (pre-assembled) spare part set

Alternative materials upon request

- * for valves size DN 80 / NPS 3 and bigger the seat is welded into the housing instead of cold-pressed
- ** for design with integrated nonreturn valve in the bypass outlet
- *** for design graphite cover gasket and sealwelded bypass flange



Excellence is our standard

6. "Inline" automatic pump recirculation valve PSG-N type 75-T

Design: Tight closing bypass

Service: Low-pressure range with a pressuredrop in the bypass up to 20 bar. Is a nonreturn valve or an orifice plate integrated in the bypass flange, the pressuredrop can be as much as 25 bar. The bypass closes normally at about 35% of the max. process-flow. Continuous operating in a range between +/- 10% around the closing point should be avoided. Normal operating points are 100% bypassflow and flows over +10% of the switchpoint. Leckagerate of the main checkvalve $\leq 0,01\%$ of the max. kv-value (EN 1349-IVL1)

Advantages: All parts can easily be exchanged, no bypass leakage, low pressurelosses

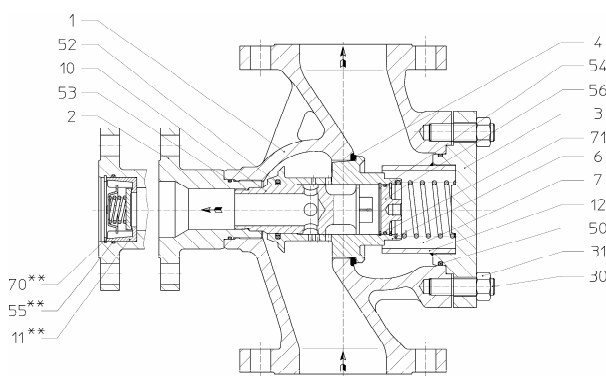

picture 15 PSG-N type 75-T

Pos.	Description	Material PN 16-40 / CL 150-300	comparable with ASTM material	Spare parts
1	body	1.0619+N	A 216 WCB	
2	flange **	1.0460	A 105	
3	cover	1.0460	A 105	
4	pressed seat *	1.4021	A 276 Gr 420	
6	check valve	1.4122	(min.13%Cr-steel)	x
7	helical spring	1.4571	A 313 Type 316	x
10	bypass bushing	1.4122	(min.13%Cr-steel)	x
11	nonreturn valve **	1.4317	A 743-CA 6-M	
12	pipe (\geq DN 80; NPS 3)	1.0305	A 106	
30	stud bolt	1.1181	A 576 1045	
31	hexagon nut	1.1181	A 576 1045	
50	o-ring ***	EPDM/NBR	EPDM/NBR	x
52	rod seal	EPDM/NBR	EPDM/NBR	
53	o-ring ***	EPDM/NBR	EPDM/NBR	
54	o-ring	EPDM/NBR	EPDM/NBR	
55	o-ring **	EPDM/NBR	EPDM/NBR	
56	stopper	1.4122	(min.13%Cr-steel)	
70	retaining ring **	1.4122	(min.13%Cr-steel)	
71	retaining ring	1.4122	(min.13%Cr-steel)	

Table 2: Partlist with standard material type 75-T

Bold face printing = stock parts up to and including DN 200 (NPS 8)
x= mark the standard (pre-assembled) spare part set

Alternative materials upon request

- * for valves size DN 80 / NPS 3 and bigger the seat is welded into the housing instead of cold-pressed
- ** for design with integrated nonreturn valve in the bypass outlet
- *** for design graphite cover gasket and sealwelded bypass flange



Excellence is our standard

7. "Inline" automatic pump recirculation valve PSG-N type 76 and 77

Design: multi stage, lever type

Service: High-pressure range with pressuredrops in the bypass between 10 and 200 bar (higher pressuredrops can be discussed). The required number of pressure reducing stages depends on the operating conditions. The bypass closes normally at about 50% of the max. processflow. Continuous operation in a range between +10% and -30% around the closing point should be avoided. Normal operatingpoints are 100% bypassflow and flows over +10% of the switchpoint.

Advantages: All parts can easily be exchanged, tight closing bypass

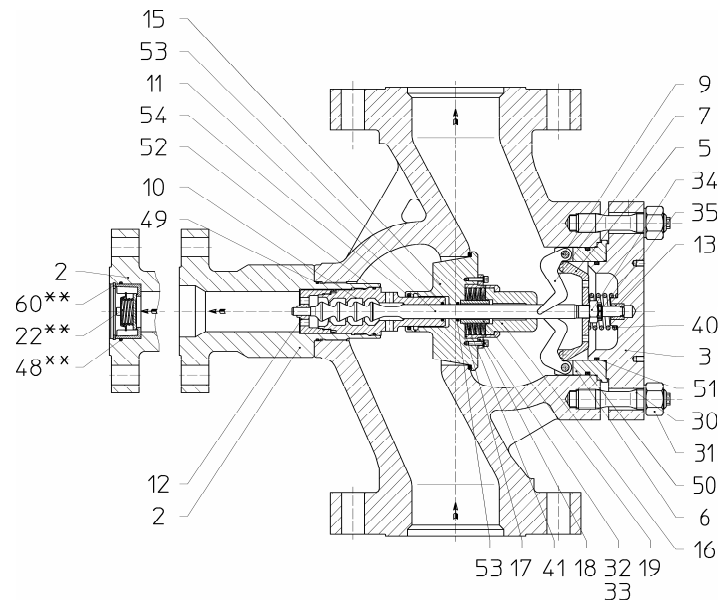

picture 16 PSG-N type 76

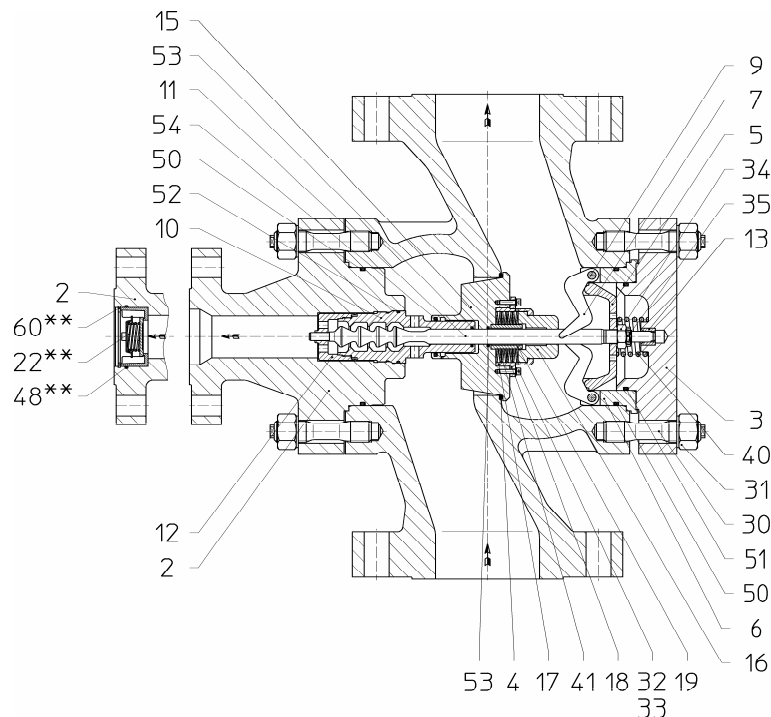

picture 17 PSG-N type 77



Excellence is our standard

Pos.	Description	Material	Comparable with ASTM material	Spare parts
1	body	1.0619	A 216 WCB	
2	flange **	1.0460	A 105	
3	cover	1.0460	A 105	
4	seat ring *	1.4021	Type 420	
5	disc	1.4122	(min.13% Cr-steel)	
6	bushing	1.4057	A276Gr420	
7	lever	1.4034	(min.12% Cr-steel)	
9	pin	1.4122	(min.13% Cr-steel)	
10	seat bushing	1.4122	(min.13% Cr-steel)	X1
11	control-plug	1.4122	(min.13% Cr-steel)	X1
12	cage bushing	1.4122	(min.13% Cr-steel)	X1
13	guide bushing	1.4122	(min.13% Cr-steel)	
15	checkvalve	1.4122	(min.13% Cr-steel)	X2
16	stop bushing	1.4122	(min.13% Cr-steel)	X2
17	guide bushing	1.4122	(min.13% Cr-steel)	X2
18	ring flange	1.4122	(min.13% Cr-steel)	X2
19	disc-spring guiding	1.4122	(min.13% Cr-steel)	X2
22	Nonreturn valve**	1.4317	A-743-CA 6-M	
30	stud bolt	1.1181/1.7709	A576/A193B16	
31	hexagon nut	1.1181/1.7709	A576/A193B16	
32	cylinder bolt	A2-70	SS	X2
33	lock-ring	A4	SS	X2
34	crown-nut	A2	SS	X1
35	cotter	A4	SS	X1
40	spring	1.4571	A 313 Type 316	
41	spring	1.4571	A 313 Type 316	X2
48	o-ring**	EPDM/NBR	EPDM/NBR	
49	o-ring	EPDM/NBR	EPDM/NBR	
50	o-ring	EPDM/NBR	EPDM/NBR	X3
51	o-ring	EPDM/NBR	EPDM/NBR	X3
52	o-ring	EPDM/NBR	EPDM/NBR	X2/X3
53	rod seal	EPDM/NBR	EPDM/NBR	X1/X2/X3
54	rod seal	EPDM/NBR	EPDM/NBR	X2/X3
60	retaining ring**	1.4122	(min.13% Cr-steel)	

Table 3: Partlist with standard material type 76 and 77

Bold face printing = stock parts up to and including DN 200 (NPS 8)

Alternative materials upon request

X1;X2;X3= mark the standard (pre-assembled) spare part sets

* for valves size DN 80 / NPS 3 and bigger the seat is welded into the housing instead of cold-pressed.

** for design with integrated nonreturn valve in the bypass outlet



Excellence is our standard

8. PSG-N selection table for valve design acc. to PN-rating

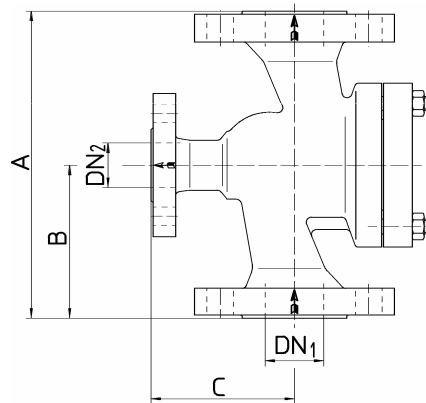

DN ₁	Type	PN	Q _{max} [m ³ /h]	DN ₂	max. Q _{min} [m ³ /h] without non- return valve	kv max [m ³ /h] without non- return valve	Code PSG-N	max. Q _{min} [m ³ /h] with non- return valve	kv max [m ³ /h] with non- return valve	Code PSG-N	A [mm]	B [mm]	C [mm]	weight [kg]		
32	75-K	10	17,4	25	6,6	2,1	05.00	5,2	1,6	05.00 R	200	100	105	16		
		16					05.01			05.01 R						
		25					05.02			05.02 R						
	40	05.03					05.03 R									
	75 / .75-T	10					9,8			05.00					6,3	05.00 R
		16								05.01						05.01 R
25		05.02	05.02 R													
40	05.03	05.03 R														
40	75-K	10	27,1	25	6,6	2,1	06.00	5,2	1,6	06.00 R	200	100	105	16		
		16					06.01			06.01 R						
		25					06.02			06.02 R						
	40	06.03					06.03 R									
	75 / 75-T	10					9,8			06.00					6,3	06.00 R
		16								06.01						06.01 R
25		06.02	06.02 R													
40	06.03	06.03 R														
50	75-K	10	42,4	25	6,6	2,1	07.00	5,2	1,6	07.00 R	230	115	115	21		
		16					07.01			07.01 R						
		25					07.02			07.02 R						
		40					07.03			07.03 R						
	75 / 75-T	10	10,0	07.00	7,3	07.00 R										
		16		07.01		07.01 R										
		25		07.02		07.02 R										
		40		07.03		07.03 R										
	75 / 300.75-T / 300.76	10	14,1	5,0	14,1	5,0	7,5	07.04	2,3	07.04 R						
		16						07.01		07.01 R						
		25						07.02		07.02 R						
		40						07.03		07.03 R						
76	63	14,1	2,0	14,1	2,0	7,5	07.04	1,6	07.04 R							
	100						07.05		07.05 R							
	160						07.06		07.06 R							
	250						07.07		07.07 R							
50	75-K	10	42,4	40	6,6	2,1	07.00	6,5	2,1	07.00 R	230	115	115	22		
		16					07.01			07.01 R						
		25					07.02			07.02 R						
		40					07.03			07.03 R						
	75 / 75-T	10	15,8	5,0	20,0	5,0	7,5	07.00	4,5	07.00 R						
		16						07.01		07.01 R						
		25						07.02		07.02 R						
		40						07.03		07.03 R						
	75 / 75-T / 76	10	27,4	2,0	27,4	2,0	7,5	07.04	2,0	07.04 R						
		16						07.05		07.05 R						
		25						07.06		07.06 R						
		40						07.07		07.07 R						
76	63	20,0	2,0	20,0	2,0	7,5	07.04	2,0	07.04 R							
	100						07.05		07.05 R							
	160						07.06		07.06 R							
	250						07.07		07.07 R							
65	75-K	10	71,7	40	6,6	2,1	08.00	6,5	2,1	08.00 R	290	145	135	43		
		16					08.01			08.01 R						
		25					08.02			08.02 R						
		40					08.03			08.03 R						
	75 / 75-T	10	21,8	6,9	27,6	6,9	7,5	08.00	5,7	08.00 R						
		16						08.01		08.01 R						
		25						08.02		08.02 R						
		40						08.03		08.03 R						
	75 / 75-T / 76	10	34,5	3,1	36,2	3,1	7,5	08.04	3,0	08.04 R						
		16						08.05		08.05 R						
		25						08.06		08.06 R						
		40						08.07		08.07 R						
76	63	24,6	3,1	31,0	3,1	7,5	08.04	3,0	08.04 R							
	100						08.05		08.05 R							
	160						08.06		08.06 R							
	250						08.07		08.07 R							
77	250	36,2	3,1	36,2	3,1	7,5	08.07	3,0	08.07 R	400	200	260	81			



Excellence is our standard

DN ₁	Type	PN	Q _{max} [m ³ /h]	DN ₂	max. Q _{min} [m ³ /h] without non- return valve	kv max [m ³ /h] without non- return valve	Code PSG-N	max. Q _{min} [m ³ /h] with non- return valve	kv max [m ³ /h] with non- return valve	Code PSG-N	A [mm]	B [mm]	C [mm]	weight [kg]
80	75-K	10	108,6	40	6,6	2,1	09.00	6,5	2,1	09.00 R	310	155	155	48
		16			8,4		09.01	8,2		09.01 R				
		25			10,5		09.02	10,3		09.02 R				
		40			11,5		09.03	11,3		09.03 R				
	75 / 75-T	10	108,6		09.00	7,9	09.00 R							
		16			09.01		09.01 R							
		25			09.02		09.02 R							
		40			09.03		09.03 R							
	76	16	144,8		09.01	7,4	09.01 R							
		25			09.02		09.02 R							
		40			09.03		09.03 R							
		63			5,6	09.04	09.04 R							
100		09.05		09.05 R										
160		09.06		09.06 R										
250	09.07	09.07 R												
100	75-K	10	169,6	50	18,3	5,8	10.00	17,4	5,5	10.00 R	350	175	185	59
		16			23,2		10.01	22,1		10.01 R				
		25			29,0		10.02	27,6		10.02 R				
		40			31,8		10.03	30,2		10.03 R				
	75 / 75-T	10	169,6		10.00	11,8	10.00 R							
		16			10.01		10.01 R							
		25			10.02		10.02 R							
		40			10.03		10.03 R							
	75 / 75-T / 76	16	226,2		10.04	8,7	10.04 R							
		25			10.05		10.05 R							
		40			6,2	10.06	10.06 R							
		63				10.07	10.07 R							
76	100	226,2	10.08	39,8	10.08 R									
	160		10.09		10.09 R									
	250		10.10		10.10 R									
	10		82,2		11.00	60,2	11.00 R							
	75 / 75-T		16		265,1	11.01	19,1	11.01 R						
			25			11.02		11.02 R						
40		11.03	11.03 R											
16		84,0	11.04	65,0		11.04 R								
76	25	353,4	11.05	16,8	11.05 R									
	40		11.06		11.06 R									
	63		11.07		11.07 R									
	100		9,2	11.08	11.08 R									
	160			11.09	11.09 R									
	250			11.10	11.10 R									
125	75 / 75-T	10	265,1	65	82,2	26,0	11.11	60,2	19,1	11.11 R	400	200	200	90
		16			11.12		65,0	11.12 R						
		25			11.13		65,0	11.13 R						
		40			11.14		65,0	11.14 R						
	76	16	353,4		11.15	9,2	11.15 R							
		25			11.16		11.16 R							
		40			11.17		11.17 R							
		63			7,7	11.18	11.18 R							
		100				11.19	11.19 R							
		160				11.20	11.20 R							
	250	11.21	11.21 R											
	150	75 / 75-T	10		381,7	80	130,9	41,4	12.00	92,1				
16			12.01	92,1			12.01 R							
25			12.02	92,1			12.02 R							
40			12.03	92,1			12.03 R							
76		16	508,9	12.04	26,7		12.04 R							
		25		12.05			12.05 R							
		40		12.06			12.06 R							
		63		15,0	12.07		12.07 R							
		100			12.08		12.08 R							
		160			12.09		12.09 R							
250		12.10	12.10 R											
200		75 / 75-T	10	678,6	100		208,7	66,0	13.00	153,1	48,4	13.00 R	600	300
	16		13.01			159,2	13.01 R							
	25		13.02			159,2	13.02 R							
	40		13.03			159,2	13.03 R							
	76	16	904,8	13.04		38,0	13.04 R							
		25		13.05			13.05 R							
		40		13.06			13.06 R							
		63		27,8		13.07	13.07 R							
		100				13.08	13.08 R							
		160				13.09	13.09 R							
	250	13.10	13.10 R											
	250	75 / 75-T	10	1060,3		125	319,4	101,0	14.00	184,0	58,2	14.00 R		
16			14.01		232,8		14.01 R							
25			14.02		232,8		14.02 R							
40			14.03		232,8		14.03 R							
76		16	1413,7	14.04	44,0		14.04 R							
		25		14.05			14.05 R							
		40		14.06			14.06 R							
		63		56,0	14.07		14.07 R							
		100			14.08		14.08 R							
		160			14.09		14.09 R							
250		14.10	14.10 R											

Upon request alternative sizes and kv-values can be quoted.



Excellence is our standard

9. PSG-N selection table for valve design acc. to Class-rating

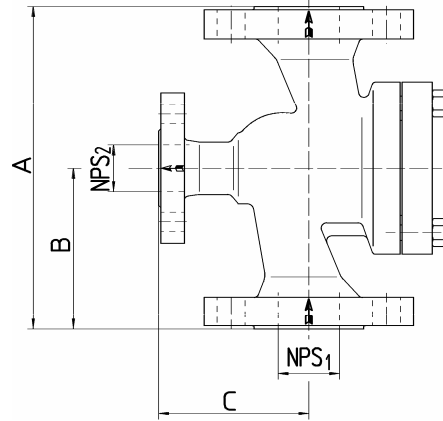

DN ₁	Type	CL	Q _{max} [m ³ /h]	DN ₂	max. Q _{min} [m ³ /h] without non-return valve	kv max [m ³ /h] without non-return valve	Code PSG-N	max. Q _{min} [m ³ /h] with non-return valve	kv max [m ³ /h] with non-return valve	Code PSG-N	A [mm]	B [mm]	C [mm]	weight [kg]
1,5	75-K	150	27,1	1	9,4	2,1	06.02A	7,5	1,6	06.02AR	222	111	120	16
		300	27,1		11,5		06.04A			06.04AR	235	118		20
	75 / 75-T	150	27,1	1	13,9	3,1	06.02A	7,5	2,0	06.02AR	222	111	120	16
		300	27,1		14,1		06.04A			06.04AR	235	118		20
2	75-K	150	44,1	1	9,4	2,1	07.02A	7,5	1,6	07.02AR	254	127	140	20
		300	44,1		11,5		07.04A			07.04AR	267	134		22
	75 / 75-T	150	44,1		5	9,4	07.02A		254	127	20			
		300	44,1			14,1	07.04A		07.04AR	267		134	22	
	76	600	58,8		2	10,9	07.05A		286	143	150	38		
		900	50,0			20,0	07.06A		07.06AR	375		188	200	65
1500		50,0	25,3	07.07A		07.07AR	375	188	200	65				
2	75-K	150	44,1	1,5	9,4	2,1	07.02A	9,4	2,1	07.02AR	254	127	140	20
		300	44,1		11,5		07.04A			07.04AR	267	134		22
	75 / 75-T	150	44,1		5	22,4	07.02A		254	127	20			
		300	44,1			27,4	07.04A		07.04AR	267		134	22	
	76	600	58,8		2	20,0	07.05A		286	143	150	50		
		900	50,0			25,3	07.06A		07.06AR	375		188	200	72
1500		50,0	25,3	07.07A		07.07AR	375	188	200	72				
2,5	75-K	150	69,5	1,5	9,4	2,1	08.02A	9,4	2,1	08.02AR	276	138	150	33
		300	69,5		11,5		08.04A			08.04AR	292	146		43
	75 / 75-T	150	69,5		6,9	30,9	08.02A		276	138	33			
		300	69,5			37,8	08.04A		08.04AR	292		146	43	
	76	600	92,6		3,1	31,0	08.05A		340	170	195	58		
		900	73,5			27,7	08.06A		08.06AR	400		200	270	81
1500	73,5	27,7	08.07A	08.07AR	400	200	270	81						
3	75-K	150	98,0	1,5	9,4	2,1	09.02A	9,4	2,1	09.02AR	298	149	175	44
		300	98,0		11,3		09.04A			09.04AR	318	159		48
	75 / 75-T	150	98,0		12,6	9,4	09.02A		298	149	44			
		300	98,0			38,0	09.04A		09.04AR	318		159	48	
	76	300	130,7		11	9,4	09.04A		318	159	48			
		600	130,7			32,7	09.05A		09.05AR	337		169	72	
900		120,5	32,7	09.06A		09.06AR	441	221	205	128				
1500		110,8	32,7	09.07A		09.07AR	460	230	140					
3	75-K	150	98,0	2	9,4	2,1	09.02A	9,4	2,1	09.02AR	298	149	175	44
		300	98,0		11,5		09.04A			09.04AR	318	159		48
	75 / 75-T	150	98,0		12,6	9,4	09.02A		298	149	44			
		300	98,0			56,3	09.02A		09.02AR	298		149	44	
	76	300	130,7		11	58,8	09.04A		318	159	48			
		600	130,7			58,8	09.04A		09.04AR	318		159	48	
900		120,5	56,0	09.05A		09.05AR	337	169	75					
1500		110,8	50,0	09.06A		09.06AR	441	221	205	133				
4	75-K	150	176,5	2	25,9	5,8	10.02A	25,9	5,5	10.02AR	352	176	215	59
		300	176,5		31,8		10.04A			10.04AR	368	184		65
	75 / 75-T	150	176,5		15,8	58,8	10.02A		352	176	59			
		300	176,5			58,8	10.04A		10.04AR	368		184	65	
	76	600	235,3		10	50,0	10.05A		394	197	215	105		
		900	217,2			50,0	10.06A		10.06AR	511		256	250	180
1500		191,5	50,0	10.07A		10.07AR	530	265	250	195				
4		75-K	150	176,5		3	25,9	5,8	10.02A	25,9		5,7	10.02AR	352
	300		176,5	31,8	10.04A		10.04AR		368		184		69	
	75 / 75-T	150	176,5	15,8	70,7		10.02A	352	176		59			
		300	176,5		86,5		10.04A	10.04AR	368			184	69	
	76	600	235,3	10	100,0		10.05A	394	197		215	111		
		900	217,2		83,5		10.06A	10.06AR	511			256	250	186
1500	191,5	83,5	10.07A	10.07AR	530	265	250	201						



Excellence is our standard

DN ₁	Type	CL	Q _{max} [m ³ /h]	DN ₂	max. Q _{min} [m ³ /h] without non-return valve	kv max [m ³ /h] without non-return valve	Code PSG-N	max. Q _{min} [m ³ /h] with non-return valve	kv max [m ³ /h] with non-return valve	Code PSG-N	A [mm]	B [mm]	C [mm]	weight [kg]	
5	75 / 75-T	150	273.6	2,5	92,6	26	11.02A	65,0	19,1	11.02AR	400	200	225	87	
		300	273.6				11.04A			11.04AR				92	
		300	364.8				11.04A			11.04AR				92	
	77	600	364.8				11.05A			11.05AR				385	240
		900	331.2				11.06A			11.06AR				300	255
1500	278.7	11.07A	11.07AR	400	260										
5	75 / 75-T	150	273.6	3	116,3	26	11.02A	92,1	22,0	11.02AR	400	200	225	87	
		300	273.6				11.04A			11.04AR				92	
		300	364.8				11.04A			11.04AR				92	
	77	600	364.8				11.05A			11.05AR				385	240
		900	331.2				11.06A			11.06AR				300	255
1500	278.7	11.07A	11.07AR	400	260										
6	75 / 75-T	150	392.0	3	130,7	41,4	12.02A	92,1	29,2	12.02AR	451	226	250	120	
		300	392.0				12.04A			12.04AR				130	
		300	522.6				12.04A			12.04AR				130	
	76	600	522.6				12.05A			12.05AR				225	
		900	482.2				12.06A			12.06AR				300	305
1500	418.4	12.07A	12.07AR	350	435										
6	75 / 75-T	150	392.0	4	120,5	11,8	12.02A	159,2	35,8	12.02AR	451	226	250	130	
		300	392.0				12.04A			12.04AR				140	
		300	522.6				12.04A			12.04AR				140	
	76	600	522.6				12.05A			12.05AR				235	
		900	482.2				12.06A			12.06AR				300	320
1500	418.4	12.07A	12.07AR	350	450										
8	75 / 75-T	150	699.1	4	235,3	66	13.02A	159,2	48,4	13.02AR	543	272	375	220	
		300	699.1				13.04A			13.04AR				230	
		300	932.1				13.04A			13.04AR				230	
	76	600	904.8				13.05A			13.05AR				390	
		900	816.6				13.06A			13.06AR				400	535
1500	716.7	13.07A	13.07AR	500	840										
8	75 / 75-T	150	699.1	6	204,9	16,2	13.06A	254,9	57,1	13.06AR	543	272	375	245	
		300	699.1				13.07A			13.07AR				245	
		300	932.1				13.07A			13.07AR				245	
	76	600	904.8				13.08A			13.08AR				400	400
		900	816.6				13.09A			13.09AR				500	550
1500	716.7	13.10A	13.10AR	500	860										
10	75 / 75-T	150	1094.5	4	235,3	101	14.02A	159,2	58,2	14.02AR	730	365	450	370	
		300	1094.5				14.04A			14.04AR				400	
		300	1459.3				14.04A			14.04AR				400	
	76	600	1391.2				14.05A			14.05AR				525	560
		900	1094.5				14.06A			14.06AR				370	
1500	1094.5	14.06A	14.06AR	430											
10	75 / 75-T	150	1094.5	6	451,7	101	14.02A	254,9	75,6	14.02AR	775	387,5	450	370	
		300	1094.5				14.04A			14.04AR				430	
		300	1459.3				14.04A			14.04AR				430	
	76	600	1391.2				14.05A			14.05AR				525	590
		900	1094.5				14.06A			14.06AR				370	
1500	1094.5	14.06A	14.06AR	430											

Upon request alternative sizes and kv-values can be quoted.



Excellence is our standard

10. "Inline" automatic pump recirculation valve with start-up flange (optional)

„Inline“ automatic pump recirculation valves with manual startup connection are mainly used for long term operation under start-up conditions.

This mode of bypass start-up operation protects the bypass unit from damages caused by fluid contaminations which are common during start-up operation. Solids can damage the seat area of the control-plug. Utilization of the manual startup connection for alternative applications, e.g. as warm-up line, can be considered too. During operation through the manual start-up line, the bypassline must be closed. The manual start-up line must be opened. Gate- or slidevalves must be installed for this purpose. Both lines must be completely filled with fluid.

If it is not possible to close the bypassline with a gate- or slidevalve during the start-up operation, the start-up flow must be at least 10% above the flow at which the bypass closes. The start-up flow can be given upon request.

The mainline behind the automatic pump recirculation valve must be closed. If not, a bigger pumpflow at a lower pumphead must be taken into account. The number of pressure reducing stages depends on the operating conditions.

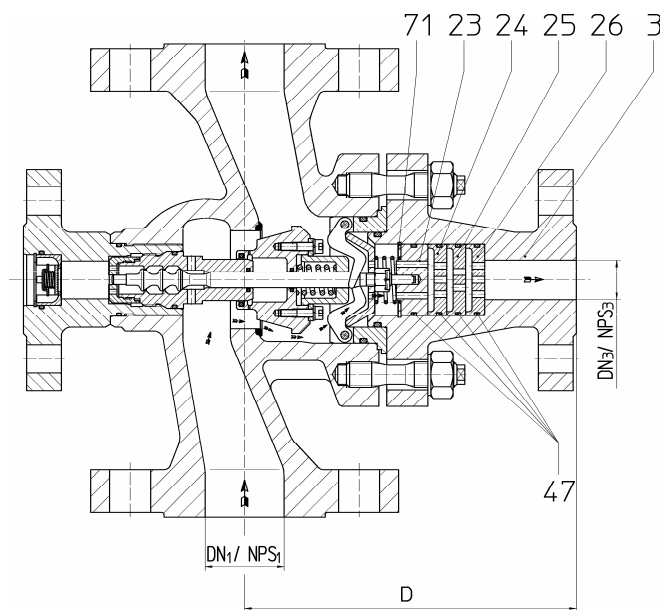

picture 18 Type 76 with start-up flange

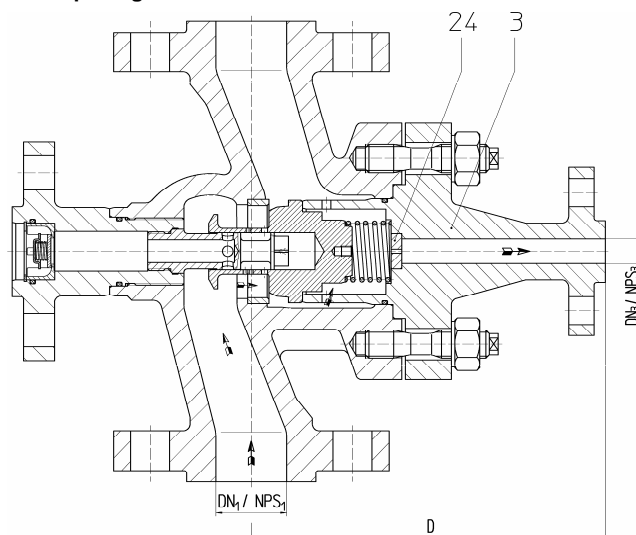

picture 19 Type 75 with start-up flange



Excellence is our standard

Table 4. Installation dimensions of the start-up connection

DN ₁	DN ₃	PN	Code number PSG-N	D (mm)
32	25	10-40	05.00-05.03H	160
40	40	10-40	06.00-06.03H	160
50	40	10-16	07.00-07.01H	165
50	40	25-40	07.02-07.03H	175
50	40	63,100,160	07.04-07.06H	210
50	40	250	07.07H	240
65	50	10-16	08.00-08.01H	195
65	50	25-40	08.02-08.03H	200
65	50	63,100,160	08.04-08.06H	260
65	50	250	08.07H	260
80	50	10-16	09.00-09.01H	225
80	50	25-40	09.02-09.03H	230
80	50	63,100,160	09.04-09.06H	270
80	50	250	09.07H	300
100	80	10-40	10.00-10.03H	280
100	80	63, 100, 160	10.04-10.06H	310
100	80	250	10.07H	350
125	80	10-16	11.00-11.01H	295
125	80	25-40	11.02-11.03H	300
125	80	63, 100, 160	11.04-11.06H	380
125	80	250	11.07H	400
150	100	10- 40	12.00-12.03H	360
150	100	63, 100, 160	12.04-12.06H	400
150	100	250	12.07H	430
200	150	10- 40	13.00-13.03H	525
200	150	63, 100, 160	13.04-13.06H	570
200	150	250	13.07H	530
250	150	10-40	14.00-14.03H	600
250	150	63	14.04H	675
250	150	100	14.05H	710

NPS ₁	NPS ₃	Class	Code number PSG-N	D (mm)
1,5	1,5	150	06.02AH	180
1,5	1,5	300	06.04AH	160
2	1,5	150-300	07.02-04AH	210
2	1,5	600	07.05AH	240
2	1,5	900-1500	07.06-07AH	270
2,5	2	150	08.02AH	225
2,5	2	300	08.04AH	240
2,5	2	600	08.05AH	290
2,5	2	900-1500	08.06-07AH	400
3	2	150	09.02AH	255
3	2	300	09.04AH	260
3	2	600	09.05AH	290
3	2	900	09.06AH	300
3	2	1500	09.07AH	320
4	3	150	10.02AH	315
4	3	300	10.04AH	325
4	3	600	10.05AH	340
4	3	900	10.06AH	370
4	3	1500	10.07AH	360
5	3	150	11.02AH	325
5	3	300	11.04AH	340
5	3	600	11.05AH	385
5	3	900-1500	11.06-07AH	400
6	4	150	12.02AH	370
6	4	300	12.04AH	380
6	4	600	12.05AH	435
6	4	900	12.06AH	440
6	4	1500	12.07AH	450
8	6	150	13.02AH	570
8	6	300	13.04AH	570
8	6	600	13.05AH	600
8	6	900	13.06AH	520
8	6	1500	13.07AH	560
10	6	150	14.02AH	630
10	6	300	14.04AH	675
10	6	600	14.05AH	780

Table 5. Material-/Partslist of the start-up connection

Pos.	Description	Material	comparable with ASTM material
3	start-up flange	1.0460	A 105
23	trestle	1.4571	A 182 F 316
24	orifice plate	1.4571	A 182 F 316
25	orifice plate	1.4571	A 182 F 316
26	orifice plate	1.4571	A 182 F 316
47	o-ring	EPDM/NBR	EPDM/NBR
71	retaining ring	1.4122	(min.13% Cr-steel)



Excellence is our standard

11. Back pressure increasing systems

The perfect protection against cavitation and evaporation is a back pressure increasing system. A leaflet for these so called back pressure regulators is available upon request.

12. Flange specifications for HORA standard valves

Pressure rating	Standard	Form
PN 10 bis 40	EN 1092	B1
PN 63	EN 1092	B2
PN 100	EN 1092	B2
PN 160	DIN 2638	E
PN 250	DIN 2628	E
CL 150 - 1500	ASME/ANSI B 16.5	RF

Upon request alternative flange configurations can be quoted.

13. Markings

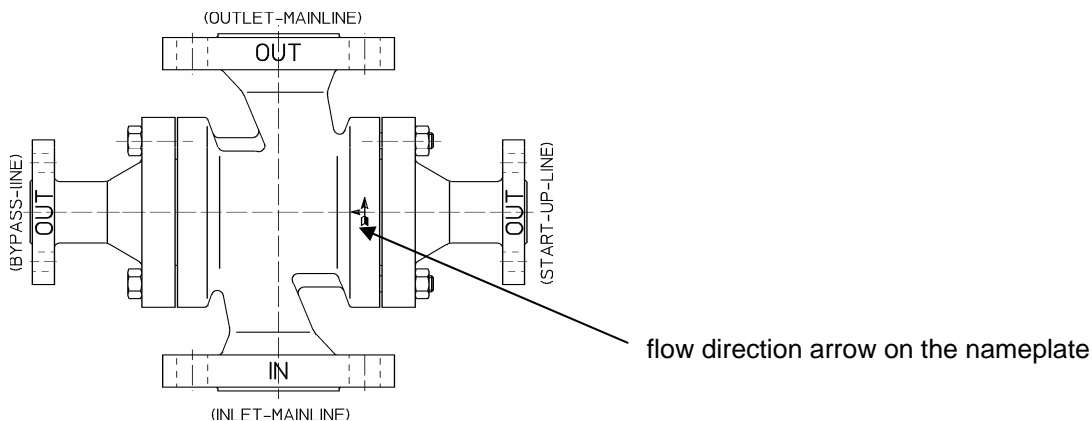

14. Testing

- Testings and markings of valves in approach to EN 1349, EN 19 (technical terms of delivery for valves)
- Mechanical technical testing acc. to EN 10213 part 2 (for casting of material GP 240 GH).
- Acc. PED 97/23/EG
- Pressure testing with water including rust-protection-inhibitor.

Special testing after consultation.

15. Rust protection

Valve inside:

All surfaces in contact with the fluid are treated with a corrosion preventive like SHELL, ESSO VALVOLINE (austenitic surfaces remain untreated). This gives protection for at least 6 months when stored inside.



Excellence is our standard

Valve outside:

Valves are painted with a single pack zinc dust primer WINCOLOR W1815 (max. temp. 200°C)
Colour: grey. Austenitic surfaces remain untreated.
Other paintings after consulting.

16. Dispatch

All flange openings are closed with a plastic cap. This cap also covers the flange facing.
The goods are normally packed in carton boxes or on pallets depending on the total shipping weight.
Depending on the mode of shipment and destination also (seaworthy) wooden boxes can be supplied by HORA.
Other packaging after consulting.

17. Storage

The valves have to be stored in a dry place with temperatures between 20°C and 60°C (rel. air humidity 65% +/-10%). The storage period should not be longer than 6 months.

18. Type coding PSG-N

DN	NPS	Code	PN	Code	CLASS	Code	Non-return valve	Start-up flange	Special configuration	Code	SS-material	Code	Product-key (<=PN 40, <=CL 300)	Product-key (>=PN 63, >CL 300)	Type
25	1	04	10	.00	150	.02A	R	H	gasket	S	1.4571	-SS	1731	1732	75
32		05	16	.01	300	.04A			special-o-ring material	S	1.4408	-SS			76
40	1,5	06	25	.02					special connections	S	1.4462	-SS			77
50	2	07	40	.03	600	.05A			special size	S					
65	2,5	08	63	.04	900	.06A			special material	S					
80	3	09	100	.05	1500	.07A			buttweld end	BWE					
100	4	10	160	.06	2500	.08A									
125	5	11	250	.07											
150	6	12	320	.08											
200	8	13													
250	10	14													
300	12	15													
350	14	16													
400	16	17													
450	18	18													
500	20	19													

example:

Inlet: NPS 2 CL 900 ANSI B16.5 RF
Outlet: NPS 2 CL 900 ANSI B16.5 RF
Bypass: NPS 1 CL 900 ANSI B16.5 RF
nonreturn valve in bypass: yes
start-up flange: yes
material seals: FKM
material body: 1.4408

Code : PSG-N 07.06ARHS-SS / 1732-77



Excellence is our standard

19. Formulas

$$k_v = Q \cdot \sqrt{\rho / (\Delta p \times 1000)} \quad k_v[\text{m}^3/\text{h}]; Q[\text{m}^3/\text{h}]; \Delta p[\text{bar}], \rho[\text{kg}/\text{m}^3]$$

$$c_v = k_v \cdot 1,156 \quad c_v[\text{USgallons}/\text{min}]$$

$$\Delta p = H \cdot 9,81 \cdot \rho / 100000 \quad \Delta p[\text{bar}]; H[\text{m}], \rho[\text{kg}/\text{m}^3]$$

20. Notes

k_v = Flow in m^3/h that flows through the full open valve at a pressuredrop of 1 bar.

c_v = Flow in US gallons/min that flows through the full open valve at a pressuredrop of 1 Psi.

Switchpoint= Processflow at which the bypass closes.

Bypass backpressure p_N = Pressure in the bypassline immediately behind the automatic pump recirculation valve at full bypassflow (normally tankpressure + static height + line losses)

21. Contacts

Holter Regelarmaturen GmbH & Co. KG
P.O.Box 1460
D-33751 Schloß Holte Stukenbrock

Helleforthstr.58-60
D-33758 Schloß Holte-Stukenbrock

Tel. +49(0)5207/8903-0
Fax +49(0)5207/88037

<http://www.hora.de>
e-mail: mail@hora.de

On our website you can find an actual list of all our international agents and distributors.



Excellence is our standard

22. Datasheet PSG-N

With enquiries/orders fill out the blank fields of the data-sheet below.

Data Sheet No.				
1	customer:		no.:	
2	plant:			
3	order no.:			
4	pos.:		p. c.:	
5	Automatic pump recirculation valve PSG-N		quantity:	
6	installation (mainline):		date of delivery	
7	inlet: DN/NPS		PN/CLASS	
8	outlet: DN/NPS		PN/CLASS	
9	bypass: DN/NPS		PN/CLASS	
10	start-up: DN/NPS		PN/CLASS	
12	<input type="checkbox"/> non-return-valve in bypass			
13	<input type="checkbox"/> BPR in bypass		HORA order no.:	
14	priming:		tests:	
15	materials	body:	type tag:	
16		internals:	documentation:	
17			drawing:	
18		seals:	part list:	
		19	medium:	
		20	temperature :	°C
		21	s. g. :	kg/dm ³
		22	pump:	
		23	normal process flow Q_{100} :	m ³ /h
		24	max. process flow Q_{max} :	m ³ /h
		25	min. process flow Q_P :	m ³ /h
		26	min. requ. pump flow Q_{min} :	m ³ /h
		27	at $Q = 0$ H_0 :	m
		28	head at Q_{100} H_{100} :	m
		29	at Q_{max} H_{max} :	m
		30	at Q_{min} H_{min} :	m
		31	pump inlet pressure p_V :	bar(g)
		32	bypass back pressure p_N :	bar(g)
		33	Δp_{Bypass} at Q_{min} :	bar
		34	Δp_{BPR} at Q_{min} :	bar
		36	$k_V-Bypass$:	m ³ /h
39	technical terms of delivery:			
40	packing:			
41	notes:			